

8' (2.5 m) ASPHALT PAVERS

RP-170/175e/ex



Highway-Class Pavers

RP-170/175

ENGINE

RP-170/175e: Tier 4F, Cummins® QSB6.7 174 hp (130 kW) @ 2,200 rpm

RP-170/175ex: Tier 3, Cummins® QSB6.7 174 hp (130 kW) @ 2,200 rpm

SHIPPING WEIGHT

RP-170: 29,280 lbs (13,281 kg)

RP-175: 32,500 lbs (14,741 kg)





Roadtec — An Astec Industries Company

Roadtec, Inc. is proud to be a part of the family of companies that make up Astec Industries, Inc. Founded in 1972, Astec Industries has grown to become America's leading manufacturer of equipment for asphalt road building, aggregate processing, oil, gas, and water well drilling and wood processing. Roadtec continues to be an industry leader together with Astec Industries, by applying Astec's model of creative thinking bolstered by a corporate culture renowned for putting customer service first.



THE ROADTEC DIFFERENCE: DELIVERING QUALITY AND INNOVATION WITH SUPERIOR CUSTOMER SERVICE

Dependability

Roadtec has been manufacturing innovative, heavy-highway equipment since 1981. We continue to grow and add new products, yet our personal connection to our customers and our ability to respond immediately to your needs is even stronger.

Customer Service

Our customers benefit from our strong focus on customer support after the sale. Field service technicians live in the regions where they work, and respond quickly. 24/7 parts support will get you the right parts fast, and at a fair price. Our product specialists will train your team on any newly purchased machine. We also offer industry-leading training at our state-of-the-art training facility and in the field.

Count on Roadtec Equipment

We don't build roads. We make the equipment so you can cost-effectively build and maintain the world's roads. With the Roadtec heavy-duty design, we are able to keep your machine working longer while lowering maintenance and operating costs. We make your operators more comfortable and confident with our user-friendly design and our customization for special projects.



VERSATILE, COMMERCIAL & HIGHWAY CAPABLE 8' PAVERS

Choose Either Track or Tire Undercarriages

Roadtec tracked pavers have a fully oscillating track frame to provide a smooth ride and lay a smoother mat. Roadtec rubber-tired pavers have great maneuverability, ride quality and traction. Hydrostatic brakes on both wheels provide precise control during operation.

RP-170e – Rubber-Tire Paver

The RP-170e is an 8' (2.5 m) wide rubber-tire asphalt paver with a compact wheelbase for greater maneuverability without sacrificed performance. The RP-170e can achieve a 30" (762 mm) turning radius, with the standard steering assist engaged, which is helpful for managing those tight spots around barriers and drains.

P-175e – Rubber-Track Paver

The RP-175e is a powerful, compact 8' (2.5 m) wide rubber-track asphalt paver designed to work in all types of sub-grades and paving applications. Full counter-rotate ability and track flotation allow the RP-175e to maneuver and pave in tight areas without sacrificing tractive effort or pushing power.

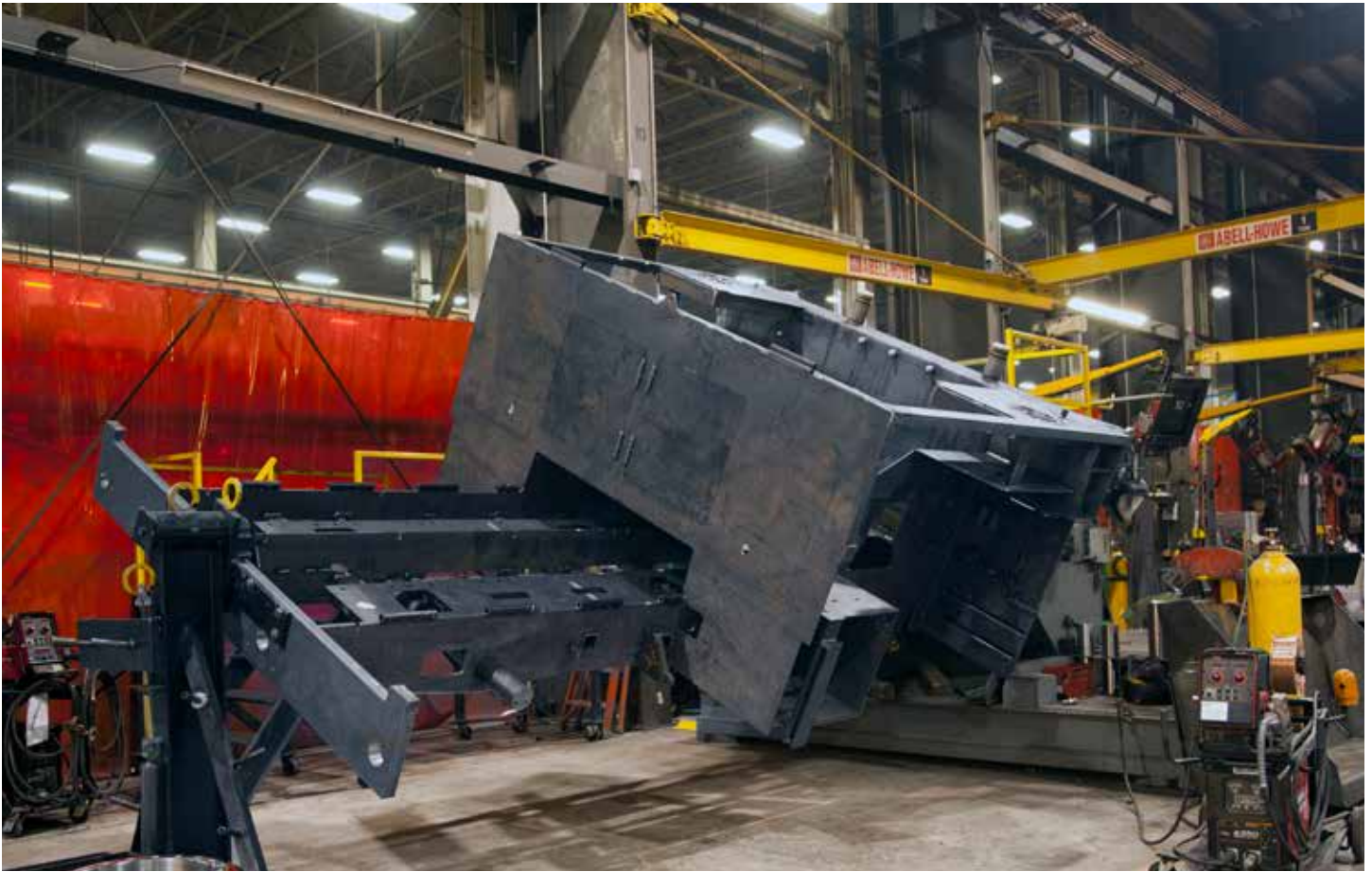

MADE FOR PAVING A GREAT MAT, IN ANY APPLICATION

Heavy Frames

All Roadtec Asphalt Pavers start with an extremely strong frame completely fabricated, welded and assembled by Roadtec professionals. The narrow shipping width of this paver allows quick and easy transportation among job locations.

Anti-Segregation

Like all Roadtec pavers, the RP-170e and RP-175e feature Roadtec's exclusive material controls with anti-segregation design. From the feed tunnel to the discharge, and the delta plates to the augers, these pavers are designed to lay the best mat in the world.

MATERIAL CONTROL IS KEY TO A SMOOTH MAT



Feed System

The conveyors on all Roadtec pavers feature a 13" (330 mm) high opening for excellent throughput, and have bolt-in wear resistant liners. Each conveyor is independently driven so material delivery can be fine-tuned for each side. The space between the conveyors has been minimized, which allows mix to be conveyed out as one uniform flow, greatly reducing segregation.

Delta Plate & Close Proximity of Augers to Conveyors

The Delta Plate defines the front wall of the material tunnel, preventing mix from rolling forward under paver, a main cause of centerline segregation. It also removes mix from the conveyors providing better conveyor efficiency. The hydraulically raised and lowered augers are placed close to the back wall and close to the ground so that there is no room for material to segregate.



Flow Gates

All Roadtec pavers come standard with flow gates, because flow gates are the best way to control the head of material. Flow gates give paver operators the ability to more finely regulate material flow. With the gates, a predetermined volume of material flows smoothly, eliminating slumps and surges.



- 1** Roadtec uses one of the industry's strongest conveyor chains for durability & performance.
- 2** Hinged, dual apron plates on the conveyors make cleanout easy and convenient.
- 3** A solid steel push bar and roller assembly on the paver engages with loading vehicles—note the thick front cross frame.

INCREASED OPERATOR COMFORT AND VISIBILITY PROMOTE PRODUCTIVITY AND SAFETY AT YOUR JOBSITE



Controls

A single joystick controls all propel functions, direction, and speed for track pavers. A tilt steering wheel controls the rubber tire pavers. Simple switches with carefully arranged layouts make using the Roadtec 8' paver easy and smooth to use. Backlit panels make all functions are accessible for night jobs just as easily as running during the day. The switches are durable, long lasting, and create a tactile operation that allows for no-look control.

Visibility

Seats of the dual operator stations hydraulically move out beyond the sides of the machine to give the operator an excellent view down the sides of the machine, back to the screed, and down to the material tunnel. On-the-fly movement allows the operator to be in the best position while paving, but also the ability to reposition when approaching trees or other overhead obstacles.



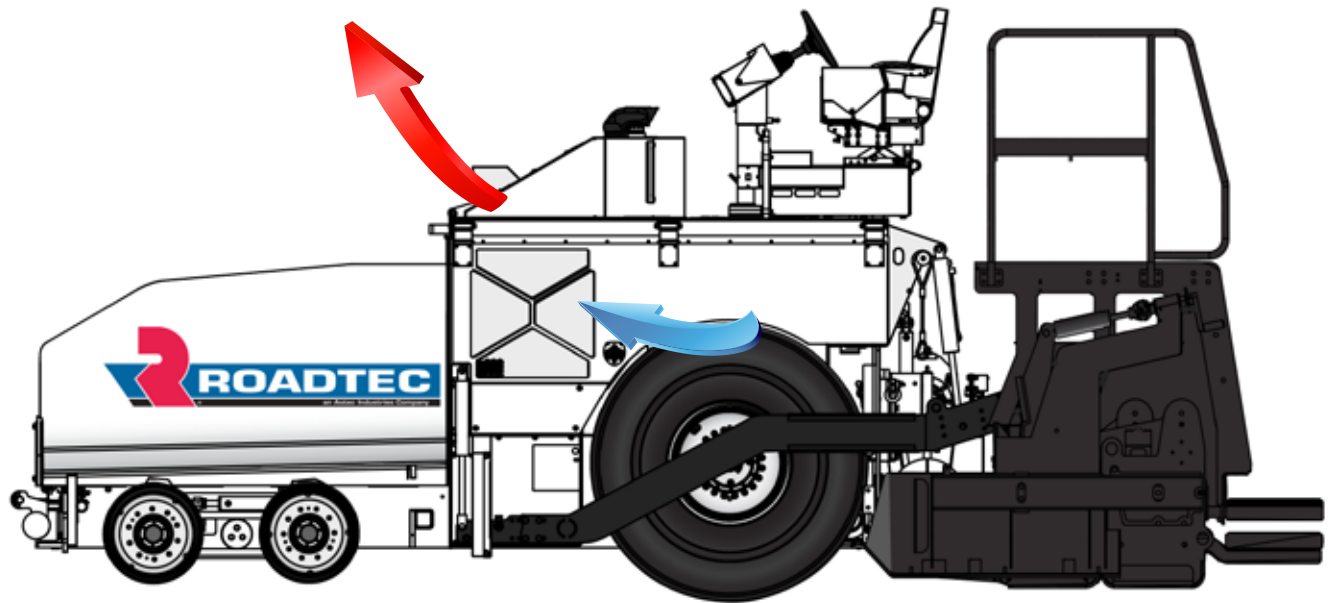

OPERATORS ARE MORE COMFORTABLE AND THE MACHINE STAYS COOLER

FXS[®] Fume Extraction

Roadtec uses a fan to draw any fumes emitted by the asphalt mix away from the crews. Fumes and exhaust are directed through vents at the front of the engine hood. This large amount of air moving over the hopper keeps the platform fume-free and cool.

Cooling Units, Redone

The cooling package, for hydraulic oil, fuel, charge air, and engine coolant, sits on the side of the machine with fresh air. Pulling air in from the side and pushing it out the front is the secret to success. This gets the coolest air possible moving across the radiators for the biggest results. The hydraulic oil tank is located under hinged doors on the operator platform.



2
ROADTEC

gp-175e

ROADTEC



EASY AND SAFE ACCESS FOR MAINTENANCE, INSPECTIONS, AND CLEANING

Unsurpassed Access

All maintenance and inspection areas are easily reached through access doors on the sides and top of the pavers. The hood lifts hydraulically and has a manual lift feature as backup. The engine compartment is room enough to make component access convenient.

Safety & Convenience

Roadtec pavers are equipped with numerous safety features. Emergency shut-off switches are found at ground level on both screed boxes and at the main operator stations. Roadtec is the only paver manufacturer to provide disc brakes on rubber tire machines. With the greatly reduced noise levels and improved visibility, Roadtec pavers allow the operator to stay in constant visual and audible communication with the rest of their crew.

PROTECT YOUR INVESTMENT AND KEEP OPERATING COSTS LOW BY MONITORING YOUR MACHINES IN REAL TIME

The Roadtec Guardian® Telematics System consists of software, on-machine displays, and wireless signal boosters to send and receive data in real time. The information can be viewed at the machine or on your computer or mobile device from a remote location.

The Roadtec Guardian® Telematics System is standard on 10' pavers and the license is automatically updated when a new version is released.

Monitor & Troubleshoot

- Grade and Slope
- Hydraulics
- Engine
- GPS Location
- Machine Codes
- Screed Heat
- Machine Speeds
- Screed Operations
- Fuel Usage
- And More



By Roadtec for Roadtec

Guardian® Telematics is for Roadtec customers who want to dramatically lower operating costs and increase productivity.

Remote Access

Log into the machine from any Internet connected computer to view machine data remotely.

Know What's Happening

Designate someone to receive auto e-mails about any fault codes that may be generated. Your team can log on to the machine and address the problem. You can also call Roadtec Service, and one of the Roadtec service technicians can dial into the machine to confirm and solve issues.

Benefit Your Bottom Line

From the moment your start using Guardian, you will see benefits, including:

- Saving on sending mechanics out into the field to find issues.
- Minimizing the time the machine is down with the ability to isolate and fix problems within minutes.
- Increasing machine life and uptime by never missing a scheduled maintenance.
- Eliminating false alarms and wasted trips.



Your machine can be located by GPS using the Guardian® system.



1 Electrical box is easily accessed from the ground.

2 Sensors continuously monitor hydraulic pressures and the values are easily accessible on the operator's display console.

3 A retractable hose for spray-down is standard and can be paired with diesel or environmental tanks.

4 Large access doors with honeycomb pattern grates allow for improved airflow and complete access to the engine. Additional access doors are found at each service point.



1

Adjustable pre-strikeoffs are standard on all our main screeds as well as on Eagle® series and Carlson® extensions.

3

A variety of contacting and non-contacting grade and slope controls are offered.

5

Two-piece, spring-loaded endgates handle grade changes.

2

Dual control stations with lockable vandal covers secure on-board.

4

Outlets provide convenient power for lights or tools.

6

Extra-wide walkways provide space for maneuvering.

SCREEDS WITH THE LATEST TECHNOLOGY AND FEATURES ENSURE SUPERIOR PERFORMANCE

To Build a Better Road You Need a Better Screed

Roadtec offers screeds that are simpler to operate and maintain and are much more rugged and functional than competing brands. That's why professional road builders rely on Roadtec® and Carlson® screeds time and time again. Each 8' (2.5 m) paver has the option of five screed versions with a variety of extension options. The screeds can be operated in single or dual grade control mode, with grade and slope control, or manually. All of our screeds are designed and built in the U.S.

Electric Heat the Right Way

Screed plates on all models are heated electrically. Just set the thermostat to the preferred temperature. Heating elements are heavy-duty, both in structure and performance, and long lasting. When elements do need to be replaced, a side door above the main screed plate provides easy access. There's no need to remove the entire plates. The elements are powered by a 34 kW generator, which provides plenty of extra current for other electrical needs. On board outlets are available for plugging in additional electrical devices.

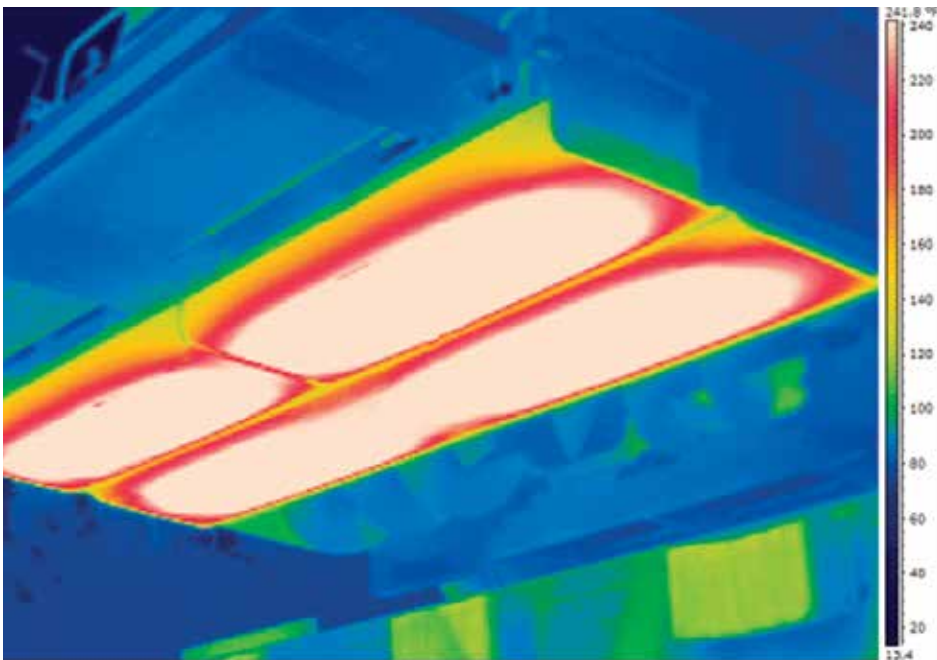

- The heat is distributed above the screed plate, ensuring even temperatures front to back and side to side.
- Heat is distributed evenly across the plate. The heating elements are heavy-duty and only need to run at 1/3 rated capacity to keep the screed hot.

S-Series Screeds: Fixed Width Bolt-On Extendable Screeds

Roadtec's fixed width bolt-on extendable screeds with hydraulic strikeoffs come in an 8' (2.5 m) version or 10' (3 m) version. Strikeoffs can be articulated from 6.6% positive to 3.3% negative. These tough, reliable screeds will serve you well for a wide range of projects.



The Carlson EZ Series: Front Extensions and Tapered Plates

The EZ Series from Carlson features electrically heated vibratory screed plates and extensions. The patented, tapered shape of the Carlson main screed plate assures that material is moved toward the outside for a uniform mat no matter whether extensions are in or out. Carlson EZ screeds also feature a food-warming oven to heat crew meals. Carlson EZIV-8 and EZIV-10 screed extensions support system uses high-strength chrome rods with adjustable composite bushings to maintain tight controls and prevent vertical movement of the extension. With an extended paving width of 15 feet (4.57 m) for the EZIV-8 and 19 feet (5.79 m) for the EZIV-10, these quick-reacting screeds are ideal for commercial paving.



SCREED OPTIONS FOR 8' AND 10' PAVERS

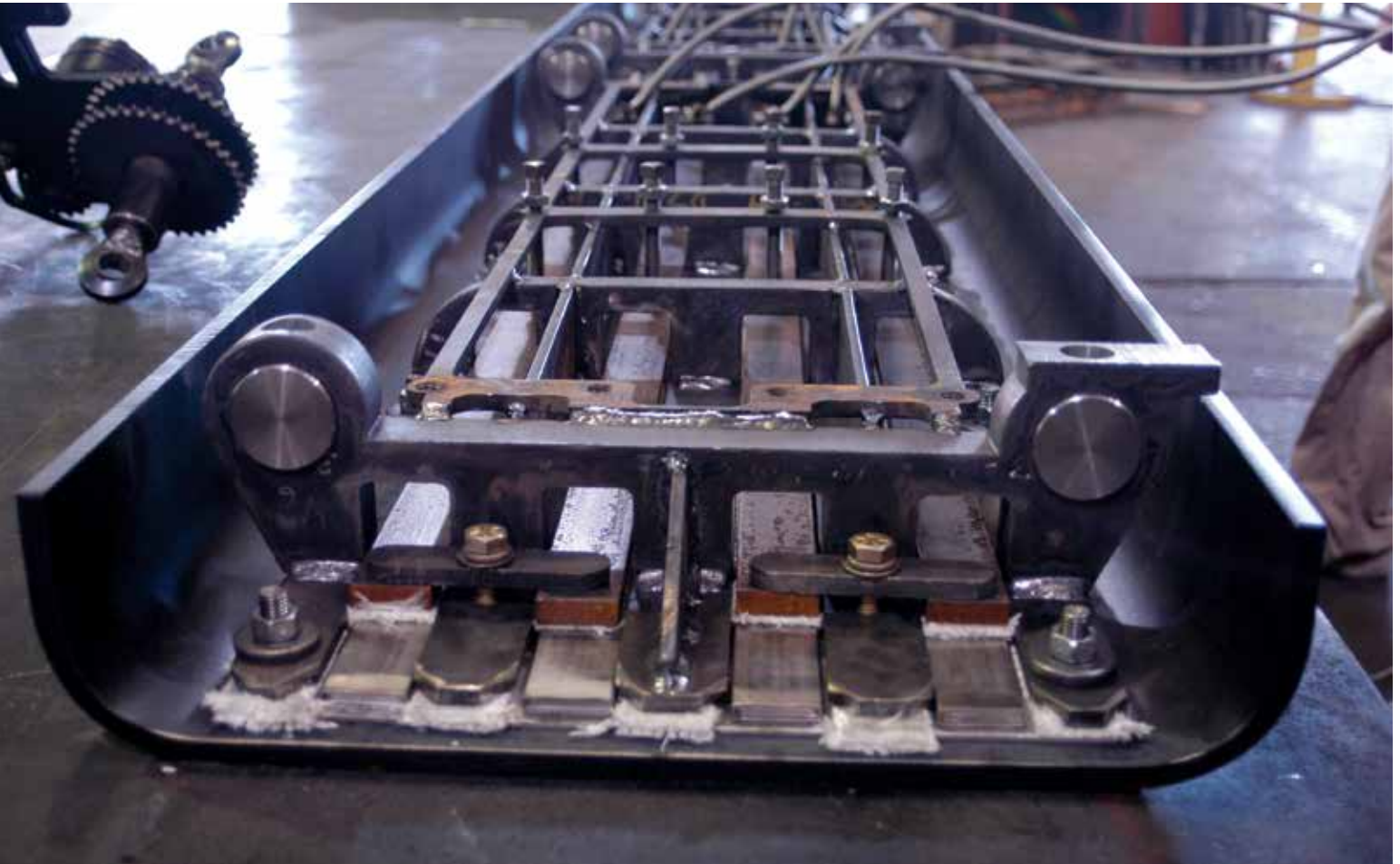

The Roadtec Eagle™ Screed: Heated, Vibratory Rear Extensions

The Eagle screed combines the latest in screed technology and heavy-duty structural design to bring you this top-of-the-line series. Heated, vibratory rear extensions let you achieve smoothness specs with ease. Thanks to the exclusive Roadtec subframe, the time it takes to remove the screed plate is half that of conventional designs. And reversible, U-shaped plates are extra stiff for a consistent mat. Add superior control features and better visibility, and you can't go wrong with this one.

Eagle Screed Highlights

Trailing (rear-mounted) extensions favor more even compaction across the mat. It's the preferred design to use when consistent mat density is key. The Eagle rear-mounted vibratory hydraulic extensions move on dual guide tubes and greaseless Teflon® bushings.

Both edges of the Eagle screed plate are curved. You can turn the plate around for a fresh leading edge and twice the wear life. That's true of extension plates, too. Adjustable pre-strikeoffs on the main screed and the extensions come in especially handy for thin-lift paving. The Eagle 8 end gates can be swung in for shipping to narrow the load to 8 feet (2.5 meters).



EDGE[®]

 **Extended Equipment Warranty
by ROADTEC**

EDGE[®] Extended Equipment Warranty

The EDGE[®] Extended Equipment Warranty is an industry leading warranty that demonstrates Roadtec's confidence in the quality and reliability of our products and our dedication to success. The Edge[®] warranty goes above and beyond current industry warranties to further protect your equipment investment from unplanned repairs. With the Edge[®] warranty, parts and labor are covered for 2 years, and up to 2,000 hours beyond Roadtec's standard warranty period of 1-year/1,000 hours. EDGE warranty gives owners a competitive edge by covering most parts at full replacement cost, not including wear components, which lowers operating costs.



OPTIONS

Additional Lighting

- Night Light Package – (6) 24v high-intensity discharge (HID) lights for higher levels of light
- SaberLight™ - (2) 92W, light panels put out excellent usable light onto the fresh mat for your crew to see
- Laser Pointer Alignment Guide - High intensity laser mounted to tractor can be positioned along line of travel to aid operator in aligning paver correctly
- Truck Dump Signal Light – LED signal light to indicate to truck driver whether to dump, stop, or lower

Front Wheel Assist - RP-170e

- Additional hydraulic motors on both rear bogies. Also available as retrofit.

Tunnel Extensions

- 12" (305 mm) tunnel extensions
- 18" (457 mm) hydraulic tunnel extensions

Auger Extensions

- 12" (305 mm), 0.75" (19 mm) thick ni-hard auger extensions. Right-hand or left hand.

6' (1,829mm) Auger & Tunnel Extension Package

- 36" (914 mm) auger and tunnel extensions for each side. Comes with all necessary hardware including outboard auger bearing supports and tunnel extension braces. Additional 12" (305 mm) auger and tunnel extension segments can be added to each side. Does not include any screed extensions.

Reversing Distribution Augers

- Retrieve material when bringing in extensions

Hopper Insert

- For use with Shuttle Buggy® MTV

Lubrication

- Automated lubrication system

Additional Sun Shade

- Includes mounting hardware

Electrical Outlets

- 4 electrical (120V) outlets located on tractor

HD Conveyor Chain Package

- Includes offset link conveyor chains in lieu of standard straight links

SPECIFICATIONS

ENGINE

- RP-170/175e: Tier 4F, Cummins® QSB6.7 174 hp (130 kW) @ 2,200 rpm
- RP-170/175ex: Tier 3, Cummins® QSB6.7 174 hp (130 kW) @ 2,200 rpm

WEIGHTS

- RP-170: 29,280 lbs (13,344 kg)
- RP-175: 32,500 lbs (16,102 kg)

CHASSIS

- .5" (13 mm) thick continuous side sheets
- 2" cross frame with 2" push plate/roller

ELECTRICAL SYSTEM

- Two 4D batteries & 115 amp alternator
- 24v system with master disconnect switch
- Electric-over-hydraulic solenoids with manual override and LED indicators

COOLING SYSTEM

- Low noise, variable speed, hydraulically driven fan

PROPEL SYSTEM

- Variable-displacement hydraulic pumps
- Two-speed hydraulic motor. Direct hydraulic, single speed planetary final drives

TIRES - RP-170

- (2) hydroflated high flotation 16x24 sand rib drive tires
- Dual 12" (356 mm) x 22" (559 mm) front bogies

TRACKS - RP-175

- 14" (355 mm) wide, steel-reinforced, smooth tread rubber track

FUME EXTRACTION SYSTEM

- Clearview FXS® fume extraction system. Clear view to the front and to the augers.

BRAKE SYSTEM

- RP-170: Hydrodynamic, service & parking brakes
- RP-175: Hydrodynamic

SPEED

- Paving speed:
170: 0-300 fpm (91 m/min)
175: 0-200 fpm (60 m/min)

- Travel speed:
170: 0-10 mph (16 k/hr)
175: 0-7 mph (12.8 k/hr)

OPERATOR STATIONS

- (2) Comfort Drive™ operator stations. Operator stations can pivot out past edge of machine for increased visibility.
- Armrest Comfort Drive™ finger tip paver function control
- RP-175: Dual electric-over-hydraulic joystick control

FRONT HOPPER CAPACITY

- RP-170: 11.5 tons (10.4 mt)
- RP-175: 10 Tons (9 mt)

FEED SYSTEM

- Independently-driven, variable-speed feeder conveyors with 400 BHN liners
- Electric flow gates for proper material distribution behind paver
- Sonic feeder control system
- Cast, 16" (406 mm) dia., 0.75" (19 mm) thick, ni-hard augers. Hydraulically raise, lower and tilt auger assembly. Rear augers can be controlled independent of feeders.

SERVICE CAPACITIES

- Fuel Tank 81 gal (308 l)
- Hydraulic Fluid Tank..... 66 gal (249 l)
- Cooling System..... 8.75 gal (33 l)
- DEF 5 gal (19 l)

NON-CONTACTING SCREED AUTOMATION

- TOPCON® sonic grade & slope control.
- MOBA® sonic grade & slope control.
- TOPCON® sonic averaging ski with hardware.
- MOBA® sonic averaging ski with hardware.

SCREEDS

ROADTEC S-8

- Standard, fixed-width 8' (2,438 mm) electrically-heated, vibratory screed. 26" (660 mm) long screed plate.
- Paves up to 24' (7.32 m) wide with extensions

CARLSON EZIV-8

- Front extendable 8' (2,438 mm), electrically heated, vibratory screed. 26" (660 mm) long screed plate.
- Paves up to 15' (4.57m) wide

ROADTEC EAGLE® 8

- Rear extendable 8' (2.44 m) electrically-heated, vibratory screed. 20" (508 mm) long "u" shaped, reversible, screed plate.
- Paves up to 15' 6" (4.72 m) wide

ALL SCREEDS

- 0.5" (12.7 mm) thick 400 Brinell® wearing surface.
- Thermostat controlled electric heat with 34 kW generator
- Standard outlets for additional lighting and accessories

SCREED OPTIONS

HYDRAULIC SCREED ASSIST PACKAGE

- For Eagle® screed. Constant up pressure on screed while in pave mode (forward and neutral).

HYDRAULIC SCREED BOOST PACKAGE

- Pressurizes screed lift cylinders when paver is stopped in neutral to prevent depression in mat. Adjustable lifting pressure. Adjustable time for pressure release with forward motion (0-10 seconds).

TRACTOR OPTIONS

- Front wheel assist
- Hydraulic tunnel extensions

RP-170 (APPROXIMATELY)

TRACTOR ONLY	29,280 lbs (13,344 kg) / 16' 3" (5,353 mm)
W/ S-8	34,580 lbs (15,685 kg) / 20' 8" (6,299 mm)
W/ CARLSON EZIV-8	35,630 (16,161 kg) / 21' 7" (6,578 mm)
W/ EAGLE 8	36,780 (16,683 kg) / 22' (6,705 mm)

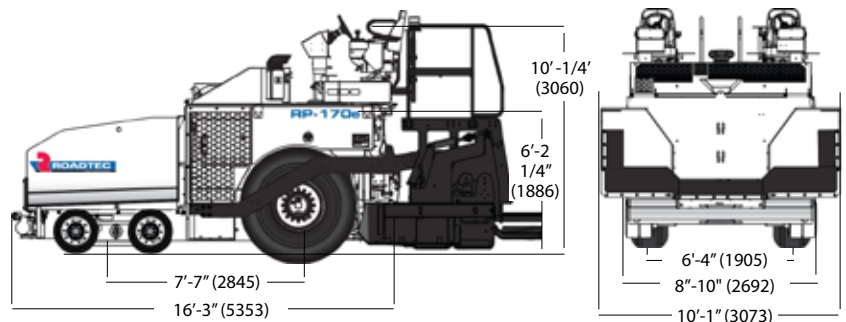

RP-175 (APPROXIMATELY)

TRACTOR ONLY	32,500 lbs (14,741 kg) / 15'-7" (4,749 mm)
S-8	37,800 lbs (17,145 kg) / 19' 3" (5,867 mm)
CARLSON EZIV-8	38,850 lbs (17,622 kg) / 20' 2" (6,146 mm)
EAGLE 8	40,000 lbs (18,143 kg) / 20' 7" (6,273 mm)

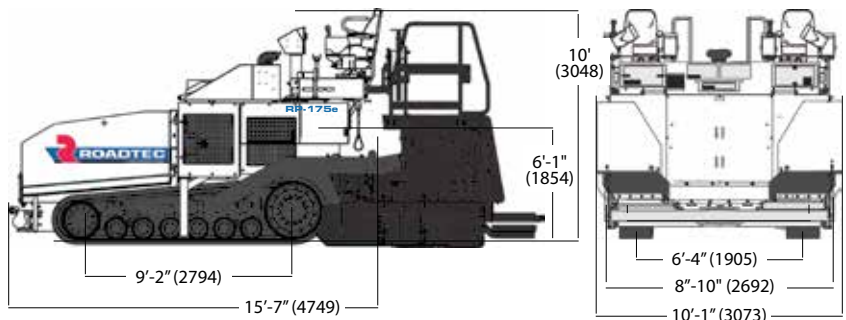

Dimensions in brackets are mm.

Specifications are subject to change without notice.



ROADTEC.COM

ROADTEC an Astec Industries Company

800 MANUFACTURERS RD • CHATTANOOGA, TN 37405 USA • 800.272.7100 • FAX 423.267.7104 • roadtec.com

190221



© 2018 Roadtec, Inc. All Rights Reserved