



# Compact Cold Planer

# **RX-300**

#### ENGINE

RX-300e: Tier 4f; Cummins® QSL 9 320 hp (239 kW) @ 1,800 rpm

RX-300ex: Tier 3; Cummins® QSL 9 320 hp (239 kW) @ 1,800 rpm

#### OPERATING WEIGHT

42,000 lbs (19,051 kg)





# A COMPACT MILLING MACHINE THAT COMBINES MANEUVERABILITY WITH HIGH PERFORMANCE

## **Overview: RX-300**

Roadtec's RX-300 compact milling machine combines maneuverability with high performance to easily operate in a wide range of applications. With a base cutting width of 48" (1.2 m) and the capability of cutting up to 12.5" (220 mm) deep, the RX-300 is excellent for both commercial applications and narrow milling projects.

## **RX-300 Cold Planers: Economical & High Productivity**

The RX-300 combines a powerful hydraulically driven cutter drum with 320 hp (239 kW) Cummins® engine to give you high productivity and functionality. The highly efficient hydraulic drum drive provides exceptional performance while reducing maintenance time. An optional VCS® Variable Cutter System enables the machine to cut at different widths without changing the entire cutter housing. The machine can easily discharge material in a wider range of environments with a 100° load-out conveyor swing capability. The RX-300 also offers solid design features, systems that are simple to troubleshoot, and parts that are non-proprietary and economical.

## Frame

All Roadtec milling machines start with an extremely strong frame completely fabricated, welded and assembled by us. This gives us complete control over the design and quality of the build. We are the only manufacturer to use A656 Grade 80 steel. This special grade of steel has twice the strength of the mild steel that is commonly used. This allows us to build stronger frame than anybody else in the industry without adding weight.

## Operator Comfort

The enhanced visibility and operator seat provide a high level of comfort on the RX-300. The simple control layout at the makes the operation more convenient and efficient.

## Dual Water Spray Bars

Roadtec milling machines have two independent spray bars to inject water in the cutter housing. The front spray bar is primarily for dust suppression, the rear spray bar cools the cutting teeth.

## Versatility

The secondary conveyor of the machine swings 50° to each side allowing the operator to easily feed a truck in difficult areas such as cul-de-sacs. The rear right leg of the machine can be positioned inside or outside of the cut with a simple single pin pivot.

## Folding Conveyor Standard

A folding secondary conveyor comes standard on the RX-300 milling machine models to aid in transport and loading.



# Options

## Miscellaneous

- Hydraulically Folding Secondary Conveyor
- Automated Lubrication System

## Additional Lighting

- Night Light Package – Four 24v high intensity discharge lights enhance visibility for work performed in the night hours

## Cutter Systems

- Variable Cutter Systems -VCS®
- Profiling or Micro-Milling Drums

## Guardian™ Telematics

- Consists of software, on-machine viewing screens, and wireless signal boosters to send and receive data at the machine.

## ENGINE

- RX-300e: Tier 4f; Cummins® QSL 9 320 hp (239 kW) @ 1,800 rpm
- RX-300ex: Tier 3; Cummins® QSL 9 320 hp (239 kW) @ 1,800 rpm

## WEIGHT

- 42,000 lbs (19,051 kg)

## ELECTRICAL SYSTEM

- 24v Can Bus system
- 105 amp alternator
- Emergency engine shut-down; cutter disengages and engine shuts down when rear cutter door is opened

## PROPEL SYSTEM

- Hydrostatic drive with automatic traction control
- Hydraulically controlled suspension. Manual and automatic.

## SPEED

- 0-3.4 MPH (infinitely variable)

## TRACKS

- Direct hydraulic, planetary track drives. Bolt on, replaceable poly track pads 10" (254 mm) wide.

## TURNING RADIUS

- Right: 6'7" (2,000 mm)
- Left: 14'9" (4,500 mm)

## OPERATOR STATION

- Right-side full-function operator station with joystick controls

## GROUND CONTROLS

- Ground Controls for mold boards, emergency stop, end gates, and drum index.

## CONVEYORS

- 24" (610 mm) wide endless, heavy-duty belts with 1/2" (13 mm) tall molded rubber cleats
- Canvas load-out conveyor covers and self-cleaning pulleys
- 100° load-out conveyor swing capability.

## STANDARD LIGHT & ELECTRICAL OUTLET

- 24-volt lights & 24-volt DC power outlets, 2 magnetic base work lights

## SERVICE CAPACITIES

- Fuel Tank .....140 gal (530 l)
- Hydraulic Fluid Tank.....33.5 gal (127 l)
- Water Tank .....380 gal (1439 l)

## MAXIMUM CUT DEPTH

12.5" (320 mm)

## AVAILABLE CUT WIDTHS

- 23.62" (600 mm), 39.37" (1,000 mm), 47.25 (1,200 mm)

## VCS® VARIABLE CUTTER SYSTEM

- Special cutter housing with segmented, hydraulically adjustable read moldboard capable of widths of 23.62" (600 mm), 39.37" (1,000 mm), 47.25 (1,200 mm)

## CUTTER DRIVE & GEAR BOX

- Hydraulic drum drive
- W-25 Fairfield® cutter gearbox with mechanical fail safe to protect engine from shock loads.

## GRADE & SLOPE AUTOMATION

- Moba Base System & Moba Ground Control Kit

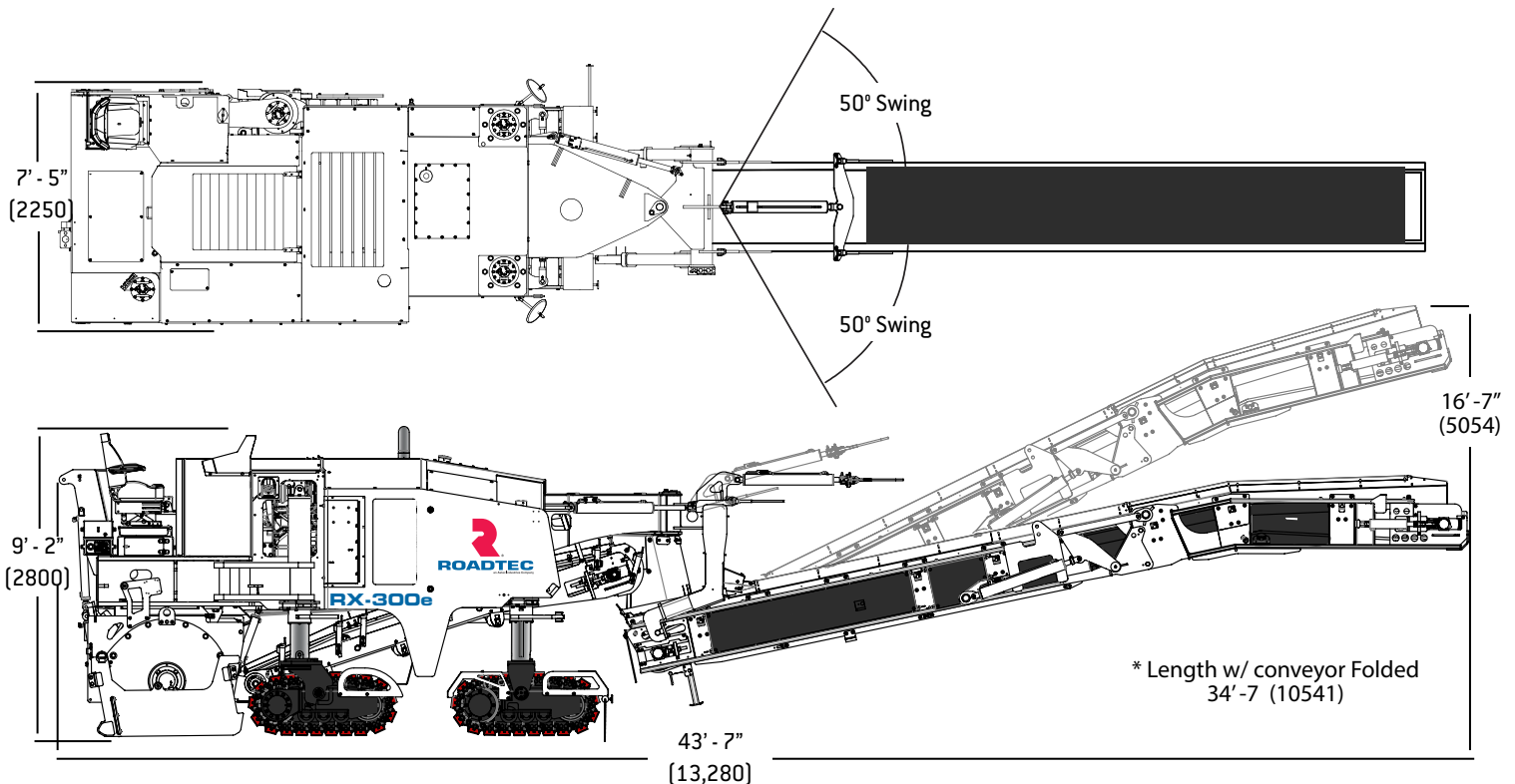

Dimensions in brackets are mm.

Specifications are subject to change without notice.